



Offset Mulcher for works of maintenance in green areas, ways, channels, gardens and agricultural works, for tractors of 35 - 80 HP.

Angulations of work: +90° / -50° and rear hood with two interchangeable positions.

Constructed in materials of high elastic limit, to reduce its weight and to be able to work with tractors of low power.

### CHARACTERISTICS

- ▶ Non-wear steel-plate chassis, thickness 8 mm.
- ▶ Rotor tubular of Ø 400 mm.
- ▶ Angulation +90° / -50°.
- ▶ 3 XPB side belt transmission.
- ▶ GIROSTOP system into the bolt of the hammer.
- ▶ Forged hammers SERRAT.
- ▶ Height-adjustable rear roller Ø 180 mm.
- ▶ PTO 540 rpm.
- ▶ Gearbox with freewheel included.
- ▶ Front protection curtain.
- ▶ Hydraulic lateral offset mulcher.
- ▶ Front skid shoes.
- ▶ Model built under EC Normative.
- ▶ Safety indicators visible to personnel.



Angulation  
+90°



-65°



### OPTIONS

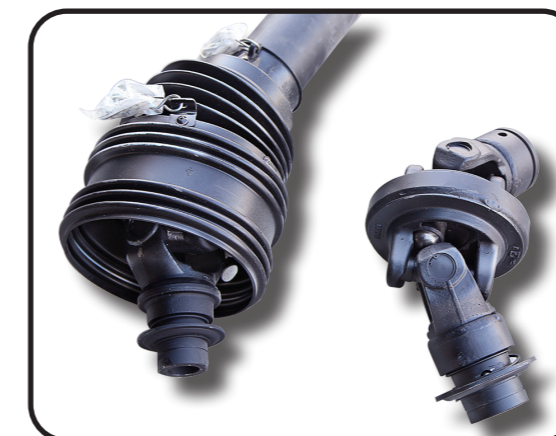

▶ Homocinetic knot

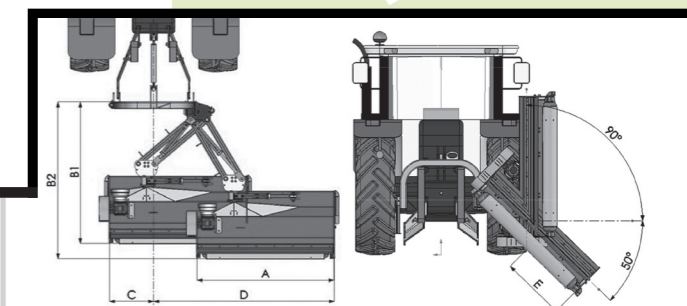

| MODEL  | mm   | KW-HP.             |    | KG  | Nº BELTS TYPE | A mm-in  | B1 mm-in | B2 mm-in | C mm-in | D mm-in  | E mm-in |     |
|--------|------|--------------------|----|-----|---------------|----------|----------|----------|---------|----------|---------|-----|
| T-1400 | 1400 | 26 - 35<br>59 - 80 | 12 | 445 | 3 XPB         | 1599-63" | 1645-65" | 1820-72" | 510-20" | 1650-65" | 535-21" | 540 |
| T-1600 | 1600 | 34 - 45<br>59 - 80 | 16 | 470 | 3 XPB         | 1799-71" | 1645-65" | 1820-72" | 510-20" | 1850-73" | 735-29" | 540 |
| T-1800 | 1800 | 37 - 50<br>59 - 80 | 16 | 500 | 3 XPB         | 1999-79" | 1645-65" | 1820-72" | 510-20" | 2050-81" | 935-37" | 540 |

